

# Advanced Accessory Module (eAAM-01)

Advanced EV Accessories in a Single Integrated Unit

New for 2024!

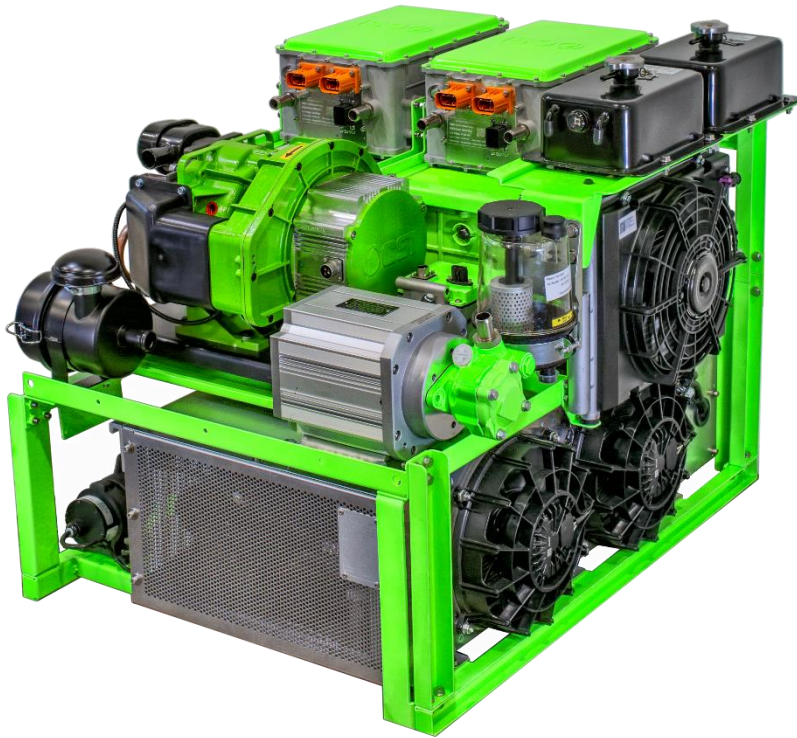

➤ All Accessory Electronics Including:

- High Voltage PDU+
- Battery Thermal Management
- Brake Air Compressor
- 3-4kW Steering Pump
- 3kW Cabin AC Compressor
- 12kW Cabin Heater
- Water Pumps for Cabin & Electronics
- 1-2 20kW AC Chargers



## PDU+ SPECIFICATIONS

### Included in PDU+

- 2.5kW 12V DCDC Converter
- 5.5kW Steering Accessory Drive
- 5.5kW Braking Accessory Drive
- Main Contactors
- Precharge Contactor/Resistor
- All Fusing
- Battery Management System BMS
- High Voltage Isolation Detection
- AC and DC Charger Control
- 40kW AC Charging Input

### Inputs

- 4 Battery String Inputs
- DC Fast Charge Input
- 40kW AC Charging Input

### Outputs

- 2 Drive Inverter Outputs (600V)
- Steering Accessory Inverter
- Braking Accessory Inverter
- 2.5kW 12V DCDC Converter
- 600VDC to AC Compressor
- 600VDC to Heater
- 600VDC High Power PTO Output
- 600VDC to other Accessories (2)



6013 Las Positas Rd., Livermore, CA 94551

[www.coulombsolutions.com](http://www.coulombsolutions.com)

# Advanced Accessory Module (eAAM-01)

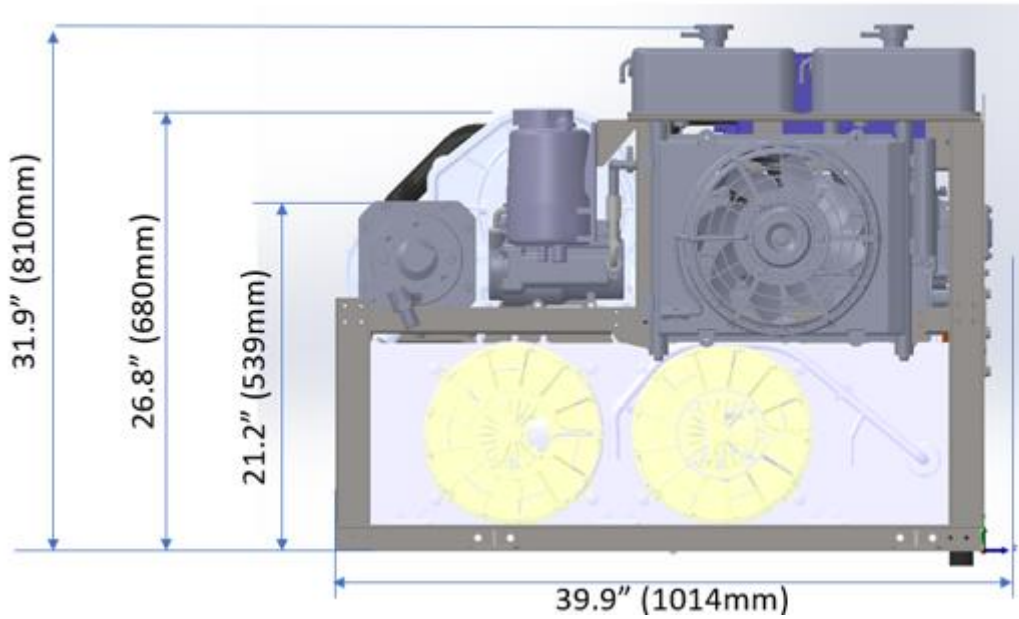

## Accessory Assembly Frame

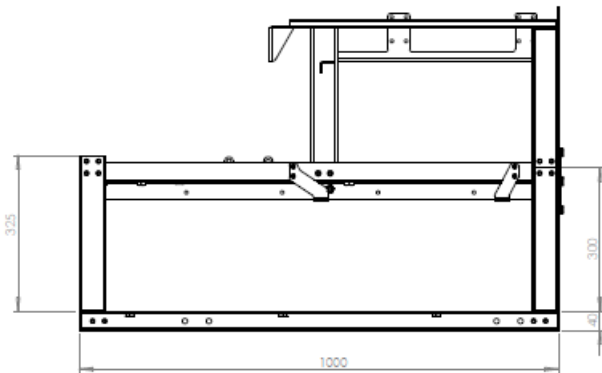
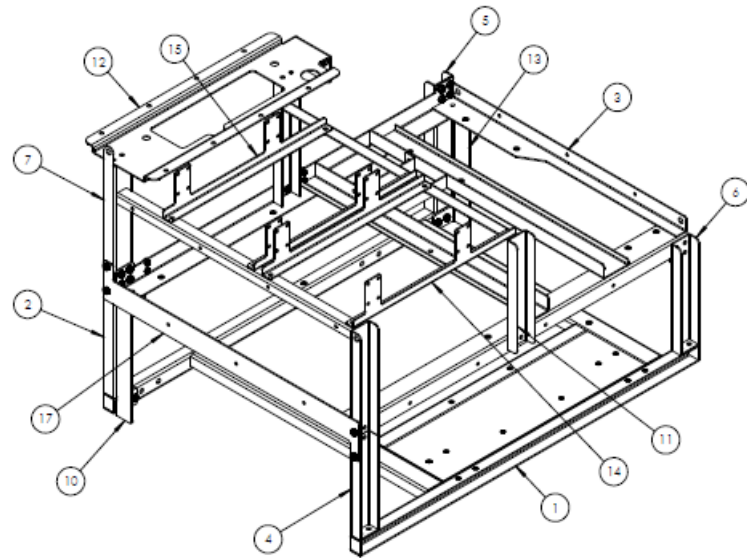
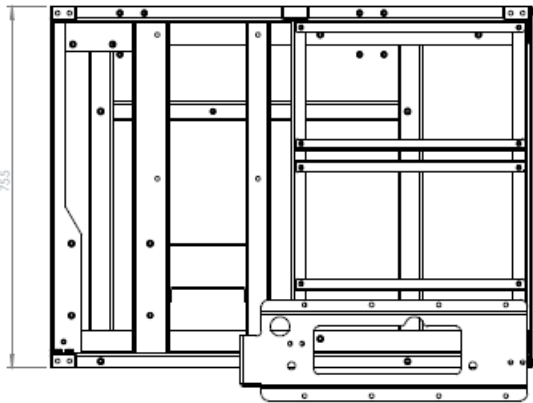

**Weight: 247kG**

**Coolant: Water Glycol**

**Refrigerant: 134a**

ITEM NO.	PART NUMBER	QTY.
1	FRAME-1	1
2	FRAME-5	1
3	FRAME-4	1
4	FRAME-9	1
5	FRAME-10	1
6	FRAME-6	1
7	FRAME-7	1
8	FRAME-12	1
9	FRAME-8	1
10	BRACE-3	1
11	FRAME-19	1
12	FRAME-11	1
13	BRACE-2	1
14	FRAME-14	2
15	FRAME-15	2
16	FRAME-18	1
17	FRAME-3	1