

CATL TX8 Battery Packs



Proven in over 350,000
Commercial EVs & HEVs



- Optimized for Commercial Vehicles
- Standardized Pack Sizes
- Narrow for Class 4-5 trucks
- Integral PTC heating
- Water/Glycol cooling
- Long Life LFP Cells
- Pack Voltage 270.5 VDC
- High Specific Energy
- ~40.5kWh Modules
- Systems from 40.5-105kWh+

GENERAL SPECIFICATIONS

Capacity per Pack	40.5kWh/Module Typical
Pack Voltage:	270.5 VDC Nominal
Specific Energy:	>140WH/kg
Cooling/Heating:	Water-Glycol/Internal PTC Strip
Environmental:	IP68
Ambient Temperature:	-30°C to 60°C
Weight:	~290 kg
Dimensions:	1720mm×520mm×240mm

* Optional 600V Battery Chiller: Model eBC7.0HV

CATL TX8 Battery Packs

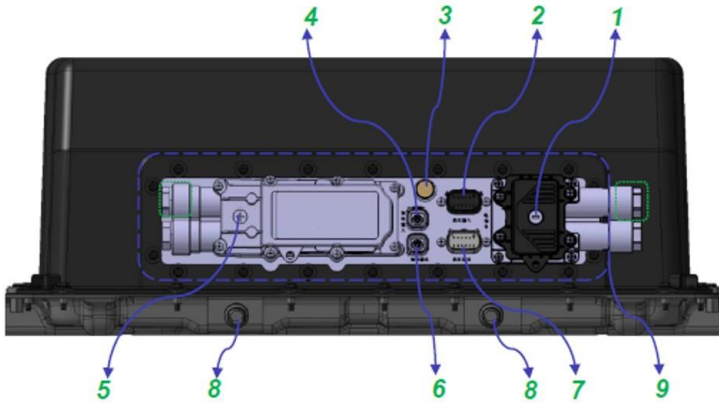

No.	Connector
1	BAT-
2	Low Voltage Input
3	Balance Valve
4	Heating Input
5	BAT+
6	Heating Output
7	Low Voltage Output
8	Coolant Connector
9	Integrated Panel

Type		High Energy	
Capacity		150Ah	173Ah
Cell dimension		33.4T*200W*207H	41T*174W*207H
Pack	TX8: 1720mm*520mm*240mm	1P84S	/
	TB1: 1080mm*460mm*240mm	/	1P40S
	TB2: 1305mm*460mm*240mm	/	1P48S
Charge rate		1.0C	1.0C
Energy density		> 140Wh/kg	
Heating		Built-in heating film	
Cooling		Built-in cooling plate	
IP level		IP68	

Basic configuration				1 string		
Cell	Volt. (V)	Cell in series	Pack in series	Energy (kWh)	Pack Number	Configuration
150Ah	540.96	168	2TX8	81.14	2	1P168S
173Ah	618.24	192	4TB2	106.95	4	1P192S
173Ah	566.72	176	2TB2+2TB1	98.04	4	1P176S
173Ah	515.20	160	4TB1	89.13	4	1P160S
173Ah	386.40	120	3TB1	66.84	3	1P120S
173Ah	309.12	96	2TB2	53.47	2	1P96S