

CATL G Battery Packs



**Proven in over 350,000
Commercial EVs & HEVs**

- **Optimized for Commercial Vehicles**
- **Standardized Pack Sizes**
- **Pack Voltages from 96-173 VDC**
- **Integral PTC heating**
- **Water/Glycol cooling**
- **Long Life LFP Cells**
- **Regular & Fast Charge**
- **High Specific Energy**
- **~30kWh Modules**
- **Systems from 90-595kWh+**

GENERAL SPECIFICATIONS

Capacity per Pack	~30kWh/Module Typical
Pack Voltage:	96, 124.8, or 172.8 VDC Nominal
Specific Energy:	~155WH/kg
Cooling/Heating:	Water-Glycol/Internal PTC Strip
Environmental:	IP68
Ambient Temperature:	-30°C to 60°C
Weight:	~205 kg
Dimensions:	950mm×630mm×240mm

*** Optional 600V Battery Chiller: Model eBC7.0HV**

CATL G Battery Packs

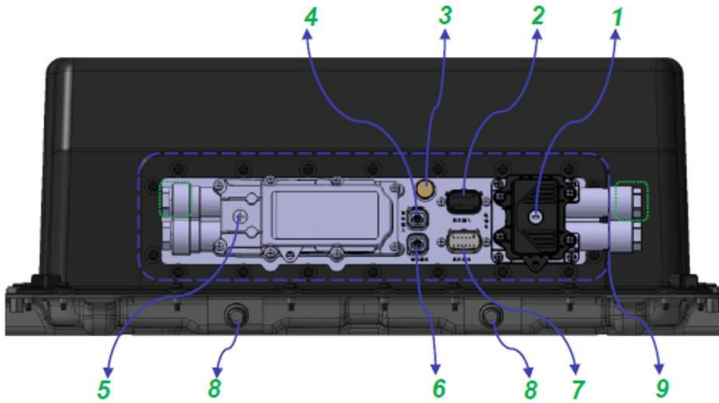

No.	Connector
1	BAT-
2	Low Voltage Input
3	Balance Valve
4	Heating Input
5	BAT+
6	Heating Output
7	Low Voltage Output
8	Coolant Connector
9	Integrated Panel

Product Type		High Energy		
Cell Capacity		302Ah	228Ah	173Ah
Cell Size		72T*174W*207H	54T*174W*207H	41T*174W*207H
Pack	C Pack: 1060mm*630mm*240mm	1P36S	1P48S	1P63S
	G Pack: 950mm*630mm*240mm	1P30S	1P39S	1P54S
Charge Rate		0.82C	1.0C	1.0C
Energy density		>155Wh/kg at pack level		
Heating		Built-in heating film		
Cooling		Built-in cooling plate		
IP level		IP68		

Cell	Basic configuration			1 string			2 strings			3 strings		
	Volt. (V)	Cells in series	Pack in series	Energy (kWh)	Pack Number	Configuration	Energy (kWh)	Pack Number	Configuration	Energy (kWh)	Pack Number	Configuration
173Ah	521.64	162	3G	90.2	3	1P162S	180.5	6	2P162S	270.7	9	3P162S
173Ah	550.62	171	1C+2G	95.3	3	1P171S	190.5	6	2P171S	285.8	9	3P171S
173Ah	579.60	180	2C+1G	100.3	3	1P180S	200.5	6	2P180S	300.8	9	3P180S
173Ah	608.58	189	3C	105.3	3	1P189S	210.6	6	2P189S	315.9	9	3P189S
228Ah	502.32	156	4G	114.5	4	1P156S	229.1	8	2P156S	343.6	12	3P156S
228Ah	531.30	165	1C+3G	121.1	4	1P165S	242.3	8	2P165S	363.4	12	3P165S
228Ah	560.28	174	2C+2G	127.7	4	1P174S	255.5	8	2P174S	383.2	12	3P174S
228Ah	589.26	183	3C+1G	134.4	4	1P183S	268.7	8	2P183S	403.1	12	3P183S
228Ah	618.24	192	4C	141.0	4	1P192S	281.9	8	2P192S	422.9	12	3P192S
228Ah	627.90	195	5G	143.2	5	1P195S	286.3	10	2P195S	429.5	15	3P195S
228Ah	656.88	204	1C+4G	149.8	5	1P204S	299.5	10	2P204S	449.3	15	3P204S
302Ah	483.00	150	5G	145.9	5	1P150S	291.7	10	2P150S	437.6	15	3P150S
302Ah	502.32	156	1C+4G	151.7	5	1P156S	303.4	10	2P156S	455.1	15	3P156S
302Ah	521.64	162	2C+3G	157.5	5	1P162S	315.1	10	2P162S	472.6	15	3P162S
302Ah	540.96	168	3C+2G	163.4	5	1P168S	326.7	10	2P168S	490.1	15	3P168S
302Ah	560.28	174	4C+1G	169.2	5	1P174S	338.4	10	2P174S	507.6	15	3P174S
302Ah	579.60	180	5C	175.0	5	1P180S	350.1	10	2P180S	525.1	15	3P180S
302Ah	598.92	186	1C+5G	180.9	6	1P186S	361.7	12	2P186S	542.6	18	3P186S
302Ah	618.24	192	2C+4G	186.7	6	1P192S	373.4	12	2P192S	560.1	18	3P192S
302Ah	637.56	198	3C+3G	192.5	6	1P198S	385.1	12	2P198S	577.6	18	3P198S
302Ah	656.88	204	4C+2G	198.4	6	1P204S	396.8	12	2P204S	595.1	18	3P204S